

Passive Elimination of Static Electricity in Oil Industry

Mičo Gaćanović¹

¹ University in Banja Luka, Faculty of Electrical Engineering Banja Luka,
78000 Banja Luka, Patre 5, Bosnia and Herzegovina

Abstract

This study explains the existing and real conditions of a possible passive elimination of static electricity when loading oil and oil derivatives. We are considering the formation and survival of gas bubbles both in the volume of oil in its depth, but also at the surface of oil and oil derivatives of the partly filled reservoir, and formation of both volume and surface electric charge in oil and oil derivatives. The study presents the research of formation and survival of static electricity in both reservoirs and tank trucks of different geometric shapes partly filled with oil and oil derivatives. We are proposing a new original possibility of passive elimination of static electricity when loading oil and oil derivatives in reservoirs and tank trucks. The proposed passive device for elimination of static electricity is protected at the international level in the domain of intellectual property (with a patent, model and distinctive mark).

Keywords : *static electricity, passive elimination, oil, reservoir, oil tank and tank truck.*

1. Introduction

The problems of technological endangerment of a safe work from the dangers caused by static electricity in the volumes of different geometric shapes, filled with oil and oil derivatives, originate particularly from the borderline area of derivative – gas-air space. It is a serious question of how to, first of all, explain and then resolve the problems of elimination of static electricity. This study is an attempt to answer the research question of possible passive elimination of static electricity when loading oil and oil derivatives. The research was both theoretical and experimental, first in the laboratory and then in the real conditions. In the first place, it is necessary to establish carriers of the electric charge in the derivative itself, in the volume, but also at the surface of oil and oil derivative in the considered volume geometry. The cases of formation and exchange of electric charge take place in the technological process of loading oil and oil derivatives. Electric charge is then transferred to the contact area of two phases of states in the area of a twofold layer, liquid phase – gas-air space, as well as liquid phase – metal wall of the considered volume. Further, the study determines and comments on the carriers of electric charge, their formation, their influence on the contact surface of liquid phase-derivative. We prove and confirm both

experimentally and theoretically their existence, by the conducted experiments both in the laboratory and in the real conditions of the working environment. To make the mentioned proof relevant in the research terms, we use a theoretical mathematics tool in the field of Applied Electrostatics, High Voltage Theory, Physics of Solid, Liquid and Gas State, as well as Theory of Perception and relevant scientific proofs, in order to mark and confirm presence of the formed electric charge. We are clarifying the formation of gas bubbles and droplets of water liquid, and the presence of admixtures – dirt, as the carriers of electric charge both in the liquid phase of the state and in the gas-air space of the partly filled considered volume geometry. The study shows results of our research of loading and storing oil and oil derivatives in the real technological work conditions. Therefore, the fact is that there happens discharging of the formed electric charges both among themselves in the volume depth, but also at the surface of the liquid phase-derivative, and also between the established contact surfaces of the twofold layer (liquid phase-gas-air space, as well as liquid phase-metal wall of the volume). We further estimate and assess by using mathematics tools the values of the formed energies of discharging, and assess the formed energies of discharging with the criterion of whether that energy is bigger or smaller than the minimal energy of ignition of the formed concentration of explosive mixture in the gas-air space of the volume (reservoir or oil tank). The criterion established here is: if the created energy of discharging electric charge is smaller than the minimal energy of ignition of the formed concentration of explosive mixture in the gas-air space, then there will not happen any accidental case with undesirable consequences. If we have the case of a bigger created energy of discharging of electric charge than the minimal energy of ignition of the established concentration of the explosive mixture in the gas-air space of volume, then there will happen an accidental case with undesirable consequences. In order to avoid an accidental case with undesirable consequences (those are explosions and fires), it is necessary to technically resolve elimination of the created static electricity in the course of loading and storing oil and oil derivatives. Led by the research fact, in the study we estimate the created conditions during the

technological process of loading, as a consequence, to be able to propose passive elimination of static electricity. Namely, the study presents a correct technical idea of passive elimination of static electricity, in the above mentioned manner and in the purposeful given use, which is in the technical performance called passive device for elimination of static electricity. We compared the to-date legally mandatory solution (presented in the technical regulations, both in our country and in the world) of elimination of static electricity in the given purpose with the help of the cam switch, by which the considered volume (reservoir or oil tank) is directly earthed. The study proves and presents relevant scientific evidence that it is exactly that kind of solution – direct earthing that causes many accidental problems (fires and explosions).

2. Creation of Gas Bubbles and Droplets

Gas bubbles and water droplets in the liquid phase of the state as a liquid dielectric, and also in oil and oil derivatives, get created by electric and mechanical manner. That happens in the technological procedure of loading of the liquid phase, which can then be located in the volume of different geometric shapes (for example, vertical cylindrical reservoir, truck tank, ordinary oil tank, etc.). In the technological process of loading (loading-in or loading-out) oil or oil derivative into the volume of a different geometric shape, there first happens input of air and then dirt of different admixtures, which are of the form and state of solid, liquid, powder and gas phase. Air and other gases create in oil and oil derivatives gas bubbles, while water and water droplets and also various admixtures of different dimensions and forms create different geometries of floating volumes. Gas bubbles and different geometries of the floating volumes of admixtures are carriers of electric charge and have dielectric characteristics different from those of oil and oil derivatives. Dielectric constants of water droplets, gas bubbles and different geometries of floating volumes of admixtures have other values of a dielectric constant compared with oil and oil derivatives and are very much different. Namely, in the procedure of the technological process of loading, the most significant contribution to forming of gas bubbles, water droplets and different geometries of floating volumes of admixtures, is in the first place *mechanical manner*. That is actually the forceful input of air, water droplets and other admixtures to the loaded oil or oil derivatives, as the necessary event of the technological procedure in the process of loading. The air itself, water droplets and other admixtures have the origin from different causes, such as: pumps, hoses, reservoir, manner of loading, kind of oil or oil derivatives, etc. Since by loading in the reservoir of the liquid phase (here: oil

and oil derivatives), they get mixed among themselves but also with the admixtures, there comes an intensive electric charge of that liquid phase. First there comes the volume ρ , and then surface electric charge η , which results in establishing electric field in the liquid phase \vec{E}_1 and then in the gas-air space of the reservoir \vec{E}_2 . Created like that in the liquid phase (for example, in the oil derivative - petrol), in the mechanical manner, gas bubbles emerge due to pressure to the surface of petrol, while water droplets and some dirt remain in the petrol volume. By establishing of electric field in the gas-air space \vec{E}_2 , of the partly filled volume of the considered geometry, and so in the depth of the petrol itself \vec{E}_1 , we as the result have that the ion atmosphere gets created first. Furthermore, there comes unification of water micro droplets into water droplets, then gas and air micro bubbles into gas and water bubbles, and unification of other micro admixtures into entireties of a different size. The presence of water in petrol results in dissolution of petrol by water under the influence of the established electric field \vec{E}_1 , and the consequence of the mentioned above is creation of the ion atmosphere and finally creation of gas bubbles. By the existence of the electric field, \vec{E}_1 in petrol there comes establishment of electric conductor paths both between petrol and metal wall of the reservoir and between petrol and “loading arm”, petrol and admixtures, and petrol and gas-air space of the observed volume geometry (reservoir, oil tank, etc.). Namely, there comes the flow of certain electric currents in the observed system, reservoir – petrol – earthing switch of the considered volume geometry.

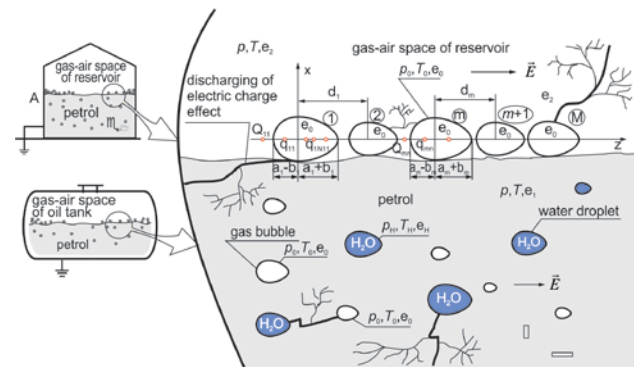

Fig. 1 Method of perception ; Presentation of possible cases of formation and then state of ovoid gas bubbles or gas cavities on the surface and inside petrol in the vertical cylindrical reservoir, which is earthed and partly filled with petrol [1,2].

The exchange of energy levels and electrostatic energy established in that manner take place even in the very inner volume of the petrol itself, both between the carriers of the

electric charge and the metal wall of the observed volume geometry in which petrol is stored, which is presented in pictures 1 and 2. The necessarily present humidity in the dielectric liquid is in a direct contact with the conductor paths and it happens that in the zone of contact humidity gets very much heated and transformed to a gas state [1-3].

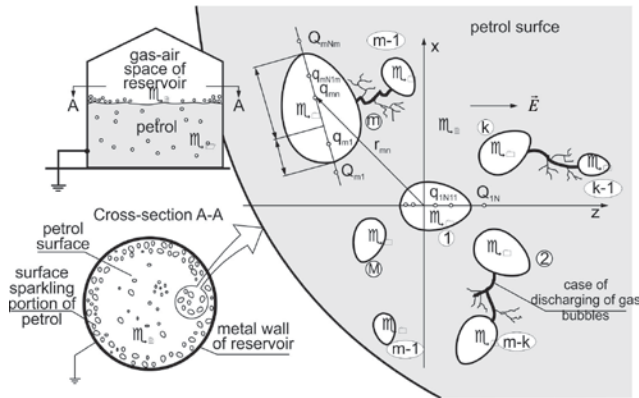

Fig. 2: Method of perception ;

Presentation of possible cases of formation and then state of ovoid gas bubbles or gas cavities on the surface of petrol in the vertical cylindrical earthed reservoir, which is earthed and partly filled with petrol [1,2].

Since water has a very much bigger dielectric constant $\epsilon = \epsilon_0 \epsilon_r$, compared with petrol, in the places in the petrol volume where the intensity of electric field is bigger, water droplets will be formed from the surrounding area out of the micro water droplets. This manner of creation of gas bubbles and water droplets is called *electric manner*. The research presentation on the existence of gas bubbles and different dirt in the depth and on the surface of petrol or oil as the liquid phase of state is presented in Figs. 1 and 2 by the perception notion called *perception method*.

2.1 Test of the perception method

Experimental test of Figs. 1 and 2, for the cases of electric charge carriers, in the metal reservoir partly filled with oil D2 (Euro diesel).

Conducting the procedure of experimental test of the perception method is valid both for the reservoir and for the tank truck, partly filled with oil or oil derivatives.

2.1.1 Experimental test – of the obtained photographs in the real work conditions.

Photographic presentation of the ovoid gas bubbles or gas cavities on the surface of oil in the metal tank truck partly filled with oil D2 (Euro diesel) can be seen in Figs 3a, 3b and 3c, as a relevant and correct research experimental evidence in the proof of here considered method of perception. Photographic film showed and proved that

there was a real event of gathering of electric charge carriers and events of their discharging on the borderline surface of oil and gas-air space of the metal earthed oil tank. At the same time, the mentioned events take place between the described electric charge carriers and metal earthed wall of the tank truck.

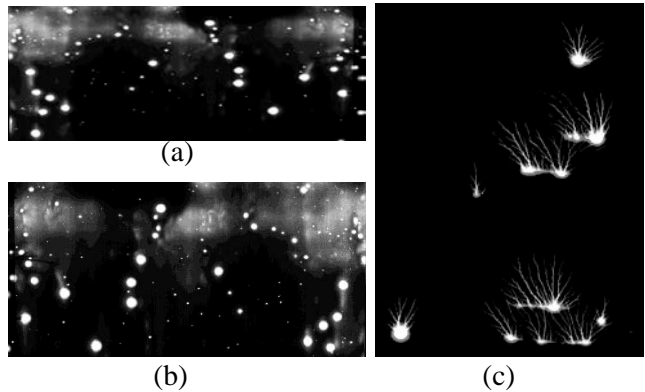

Fig. 3: Description of pictures ;

Photographic presentation with the medical photographic film – by using the procedure of long exposure, of the surface of charged oil D2 (Euro diesel) in the partly filled and earthed tank truck, made in the Oil Refinery (Bosanski) Brod-loading racks, in December 1986, where: bigger ovoid stains are gas bubbles as electric charge carriers that are in the phase of discharging; smaller white stains are different admixtures (dirt) as electric charge carriers in the phase of discharging; illuminated clouds mark the events of discharging inside oil at its depth. Discharging takes place both among the electric charge carriers and between the metal earthed wall (barrier) of the tank truck [1, 2].

Note Fig. 3; set medical photographic film (used for photographing and diagnosing the state of human lungs) was removed from the surface of oil in the tank truck by around 110 cm. We do not describe here the procedure of setting medical photographic film when photographing the events.

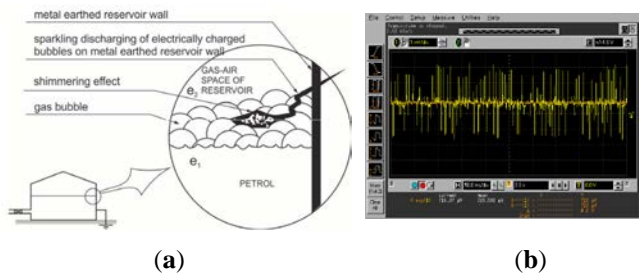

Fig.4 Method of perception and proving [1, 2]:

(a) picture presentation by the perception method of a possible accidental case of discharging of the electric charge carriers on the surface of the liquid phase (for example, oil or oil derivatives) towards the earthed metal barrier of the vertical cylindrical reservoir, [5-7];
 (b) proof of the method of perception: existence of the possible accidental case presented in picture a) visible by the intelligent oscilloscope.

Claim Fig.4: We assess and confirm that the same events take place in all kinds of volumes, of different geometric

shapes, for storage, transportation and loading of oil, oil derivatives, dangerous and flammable liquids and gas. The most dangerous event when loading oil and oil derivatives is the one of a possible discharge of electric charge in the gas-air space between the electric charge carriers from the surface of the considered liquid (for example, oil and oil derivatives) and metal earthed wall (barrier) of the tank truck (or reservoir or some other considered volume geometry) [1, 2]. The study of the influence of a gas bubble in dielectric liquids and gas-air space of the reservoir is very complex and scientifically represents a very complex multi-disciplinary physical-chemical process, which unifies a great number of very complex natural phenomena. With regard to the influence of the form and size of a gas bubble, the gas bubble in the literature is approximated by a ball [3]. The gas bubbles, which get formed in the liquid dielectric and gas-air space, gather in the zones where the electric field is most homogenous, and the breakthrough happens exactly on those places [1, 2, 4]. That represents a big danger in the technological processes of loading liquid easily flammable dielectrics. The mentioned danger is defined by the term of a great danger in storing, transporting and loading of easily flammable and explosive liquids, and in the literature it is called a danger of static electricity. All liquid dielectrics have their physical (rigidity, color, viscosity, density, liability to evaporation, etc.), chemical (chemical stability, acidity, content of admixtures) and electrical characteristics.

2.1.2 General electrical characteristics of the liquid dielectric are:

dielectric rigidity, specific resistance, relative dielectric constant and coefficient of dielectric losses. Dielectric rigidity of the liquid and gas-air space of the reservoir, E_{pr} which is filled with explosive and flammable mixtures, is a significant characteristic. It represents a measure for assessing the capacity of the liquid dielectric, i.e. gas-air space of the reservoir, to withstand the electrical strain created by electric charge or static electricity both in and on the surface of the liquid in the reservoir (or some other volume), Fig. 4. Dielectric rigidity of the dielectric E_{pr} , is defined as the breakthrough voltage U_{pr} , reduced to the distance between the examined electrodes d , i.e. $E_{pr} = U_{pr} / d$. The value of dielectric rigidity E_{pr} , for petrol is 40000 kV/m to 49000 kV/m [18-20]. Oil and its derivatives according to their electrical characteristics belong to dielectrics, which are characterized by the relative dielectric constant $\varepsilon \in (1,3)$ and specific electrical resistance $\rho \in (10^9, 10^{13}) \Omega m$, [18]. In the real conditions

of loading oil or oil derivatives at the distance d , spark discharging or sparking may happen among the grouped electric charges, but also towards the wall (barrier) of the earthed reservoir. The term of a grouped electric charge means the electric charge placed in the form of a cloud in the liquid itself or at the surface of the liquid (in the concrete case it is petrol), which is represented in Fig. 1, 2, and 3. Arcing or sparking among the grouped electric charges and towards the metal wall of the earthed reservoir is an unavoidable event, both in the course of loading liquid, but also at the time of relaxation of the liquid. The reason for that is that the earthing of the metal wall of the reservoir or oil tank essentially represents closing of the electric circuit of the model of oil tank (or reservoir) and bringing the metal wall to the certain potential, [18, 19, 21]. The value of the spark energy, W_{spark} is an important piece of information in order to assess the danger caused by the static electricity. The criterion for the assessment of the latent danger caused by the static electricity is, $W_{spark} = 0.4W_p$, where W_{spark} - is energy of ignition of the formed explosive mixture in the gas-air space. The spark in the liquid is not that dangerous as when it appears in the gas-air space of the partly filled reservoir, tank truck or other volume, [1-3, 18]. It is important to note that sparking in a described manner is not either avoided or eliminated if the metal reservoir or some other volume are earthed through the outer metal wall. The distribution of the volume electric charge, ρ , in the reservoir itself, on the occasion of the technological process of loading, gets changed in time t , [1-3, 18].

3. Generating of Static Electricity in the Technological process of Transportation and Storage of Oil and Oil Derivatives

3.1 Theoretical explanation : model of a metal tank truck

The distribution of oil and oil derivatives (hereinafter: fuel) requires their transportation between certain locations. Transportation implies loading of fuel into oil tanks, its transportation to the specified destination and its loading to adequate reservoirs for the purpose of storage. During the transportation of oil, no matter whether it implies loading or transportation, its molecules get affected by the forces of mechanical and thermal origin. Under the effect of these forces, what happens in the derivative is generating and then discharging of the static electricity towards the metal wall of the tank truck, which in the presence of easily flammable gas mixtures may cause

undesirable consequences, like fires and explosions. The flammable gas mixtures get created as the result of a diffuse movement of the molecules of the evaporated fuel and surrounding air, [1-3,18].

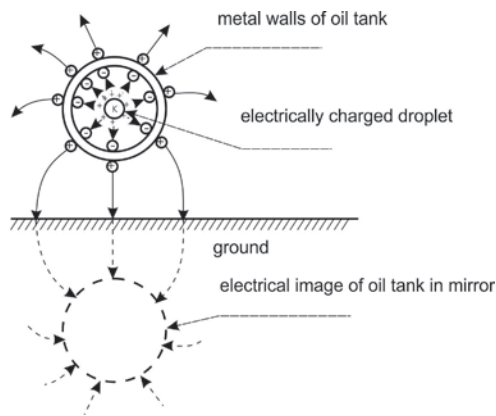

Fig. 5 Presentation of the model of a metal tank truck for transportation of oil and oil derivatives, [1, 2].

The electric model of the oil tank for transportation of fuel is presented in picture 5. During the transportation or loading of liquid fuel there happens a mutual contact of its layers and also its contact with the walls of the metal oil tank, which results in generating of an adequate electric charge.

That is a result of the transfer (conversion) of the mechanical into the electric energy [1, 2]. A portion of the mechanical energy, which is by friction transformed into heat, in a certain way also affects the final result in the formation of static electricity in the derivative (fuel). The charged particles of fuel in presence of foreign substances, like water, air and particles of dust, and existence of the established electric field, result in the formation of a sparkling part made of charged bubbles, which under the effect of the buoyancy force in the liquid fuel emerge to the surface, [1-3]. If the electric charge of the gas bubbles on the surface of the liquid part of the fuel remains as a constant, what may happen is an increase of the value of the established electric potential on its surface.

The geometric dimension of the gas bubble now gets decreased under the effect of the mechanical and thermodynamic processes in the fuel. With the increase of the electric potential of the surface of the created gas bubble, the intensity of the electric field also gets increased. When the intensity of the electric field on the surface of the gas bubble gets bigger in its value than the dielectric rigidity of the surrounding air, which amounts to, $1 \text{ KV/mm} \div 3 \text{ KV/mm}$, the bubble becomes electrically unloaded. What also takes place is the disturbance of the mechanical and thermodynamic balance and its splashing into the surrounding area in the form of tiny charged droplets of fuel that float in the oil tank above the level of

the liquid part of fuel. One of these droplets, in Fig. 5, is represented by K, with a positive electric charge. Let us mention, and we shall also show that later on, that due to foreign admixtures in oil, the charged droplets, i.e. vapors above the liquid part of the fuel, may have both positive and negative electric charge, [1, 2]. The positively charged droplet K from picture 5 represents a source of the electric field, the distribution of which is such that it flows into the inner surface of the metal oil tank at the right angle. At the same time it represents a condition of the static regime of work of the considered created electrostatic system. Under the influence of the electrostatic field in the metal walls of the oil tank, the induced electric charge gets generated, negative one from the inner and positive ones from the outer side of the oil tank, which are represented by adequate circles (Fig. 5) with the signs written in them, “ - ” as minus and “ + ” as plus. The negative and positive induced charges on the inner and outer surface of the oil tank wall bring about the induced field in the metal wall that is equal in its intensity to the field of the charged droplet, K, but of an opposite direction, because of which the total value of the electric field in the metal wall of the earthed oil tank amounts to zero.

The electric field out of the metal oil tank, in accordance with Maxwell’s postulate, originates from the positive induced electric charges and spreads through the surrounding area, as presented in Fig. 5 [22-28].

Since the surface of the Earth in different circumstances acts practically as an ideal conductor plane, the electrostatic system of *charged oil tank - earth*, acts as a loaded capacitor, in which the oil tank surface represents a positive coating and its reflection in the mirror with regard to the surface of the earth a negative coating [1,2, 18].

On the other hand, the electrostatic system: charged droplet K – inner surface of the metal oil tank, also represents a loaded capacitor, in which the surface of the charged droplet K plays the role of a positive coating, while the inner surface of the metal oil tank the role of a negative coating. Since the radius of the droplet K is significantly smaller than the radius of the oil tank, the radius of the oil tank may be considered as infinitely big. Namely, we can consider the oil tank as if it acts as having a spherical shape.

Based on that, the system, charged droplet K – metal oil tank, can be treated as a spherical capacitor with an infinitely big other coating, i.e. as a lonely charged sphere, the radius of which is equal to the radius of the charged droplet K [1, 2].

In the real circumstances, the charged gas mixture is composed of a huge number of charged droplets $K_i, i = 1, n, n \rightarrow \infty$. The mean value of the potential of all droplets, if these mutually according to dimensions and quantity of intensity do not differ much, equals :

$$\varphi_{ksr} = \frac{1}{2} \sum_{i=1}^n \varphi_{ki} = \frac{1}{n} \sum_{i=1}^n \frac{q_{ki}}{4\pi\epsilon r_{ki}} \approx \frac{q_{ki}}{4\pi\epsilon r_{ksr}} \quad (1)$$

where q_{ki} and q_{ksr} - are corresponding values of the quality of electricity of individual droplets K_i and their mean value, and r_{ki} and r_{ksr} - are values of the radius of individual droplets K_i and their mean value, i.e.

$$q_{ksr} = \frac{1}{n} \sum_{i=1}^n q_{ki} \quad \text{and} \quad r_{ksr} = \frac{1}{n} \sum_{i=1}^n r_{ki} \quad (2)$$

The parameters on the borderline surface of two dielectrics are: mechanical forces, normal and tangential component of the electric field and conductor solid particles of dirt in the liquid dielectric, [4-14, 18-20].

4 Generating of Static Electricity: Experimental Test in Transportation and Storing of Oil and Oil Derivatives, Example: Metal Tank Truck Partly Filled with oil D2 (Euro diesel)

The new status of the technical-technological knowledge in innovating intelligent technical equipment and devices, meant that we could conduct a research experimental test of the regularity and correctness of the *Method of perception and proving*. Namely, we conducted the experimental test of generating static electricity in the technological procedure of transportation and storage of oil and oil derivatives with the metal tank truck partly filled with oil D2 (Euro diesel). In Fig. 6 we can see the events of changing the standardized values of the established electrostatic charge on the surface of oil with regard to the metal wall of the tank truck. Actually, the mentioned events are also an experimental test of both the *theoretical postulate* of events, but also of the part of claim of the *Method of perception*. The tank truck was parked at the loading area for loading oil derivatives (at the petrol station) and oil was loaded from the tank truck to the underground steel reservoir. We got an oscillographic picture of the events in the interior of the tank truck in the real technological conditions on the considered borderline surfaces of the gas-air space of the tank truck twofold layer contact: gas environment of oil – metal wall. The obtained changes of the caused events are manifested in the technical manner offered by this intelligent equipment, [1, 2]. This experimental test is at the same time a theoretical proof of the existence of electric charge carriers

both in the volume of oil in its depth and also on the surface of oil.

4.1 Analysis of the impulse signals obtained by an oscilloscope, [1, 2]

The analysis of the obtained impulse signals in the described experimental test and recorded by the use of an intelligent memory oscilloscope, are set as a basis for applying statistical methods in determining important experiment parameters. Those parameters are of importance for undertaking the precaution measures in transporting and loading of oil, but also in the synthesis of adequate passive sets for elimination of static electricity. In the conducted analysis of the experiment, in the part of a possible passive elimination of static electricity, the condition is set so that the passive sets, presented in picture 9, are responsible for causing fires and explosions in the gas-air space of the tank truck, and also in the reservoirs and other similar volume geometries. We shall not describe here the procedure of recording oscillographic impulse signals, because it is technically very demanding and in the realization technically complex. By determining the probability of the distribution of these signals on the amplitude in the period of duration, we get the basic data for assessing the probability of overstepping the values of energy of fuel ignition in the determined time interval and along the already set technical conditions. On the other hand, for the purpose of a synthesis of the system of technical protection by the passive device for elimination of static electricity and certain reliability of its work, coming from the experimentally obtained stochastic parameters as unavoidable events, we perform determination of the necessary technical conditions of protection. We shall achieve the safe technological realization of loading oil if we undertake the measures of protection and elimination of static electricity. To realize this, it is necessary to analyze the obtained oscillographic impulse signals of discharging the established electric charge with the research task and the goal of finding possible passive elimination of static electricity.

Comment: In Fig. 6 it is visible that at the moment t_1^N the outer metal wall of the tank truck gets charged by positive electric charge – which is proved by a standardized positive one-direction component of the voltage of $690\mu V$. With that value of the electric charge of the metal wall of the tank truck, there are visible changes taking place on the borderline surfaces of both the charge and the potential, expressed in the impulse regime with positive and negative impulses. We neglect minor impulse changes in this regime of changes, because they are at the level of a murmur. We consider distinct impulse changes as inter-

electrode discharging among the very charge carriers in oil (gas bubbles and different admixtures – dirt), but also as discharging between the charge carriers and the metal wall of the tank truck.

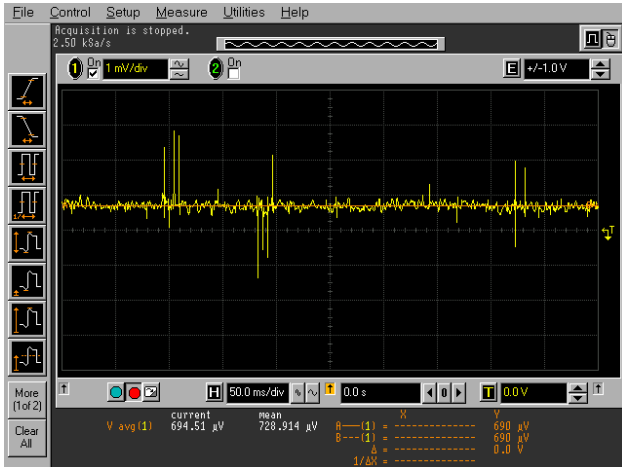

Fig. 6 : Oscilloscopic presentation of the events on the borderline surface of oil – gas-air space of the tank truck in the real work conditions, at the moment of t_1^N , [1, 2].

4.2 Probability of generating impulse signals in the amplitude domain, [1, 2].

Experiment postulate: The experiment of electric charge of oil D 2 (Euro diesel) and monitoring of the differential impulses at the exit by the use of the intelligent memory oscilloscope, took place with the speed of loading oil in the period of duration of loading with the interval of 15 minutes.

The application of the intelligent memory oscilloscope resulted in memorizing and recording on the plotter of the time diagrams of voltage u_{12} - which represents the exit voltage of the tank truck as the created generator of the electricity quantity (*tank truck – ground*), where the capacitor of the capacity C_{12} - represents the capacity of the tank truck with regard to the ground.

In the contact of the twofold layer *liquid phase state* (oil) and *solid phase state* (earthed metal wall, or barrier, of the tank truck) of the borderline area, what gets established is *differential capacitance* C_d .

This capacitance is made up of a twofold layer, from one side the contact of *oil* (the form of a sparkling phase), and from the other side – *metal wall* (barrier) of the tank truck. The established dielectric of the differential capacitance C_d , is the present sparkling phase along with the present charged condensed droplets of oil with the charge $t \square t_i$, which are gathered in time $t \square t_i$. We made a recording of

the time diagram on the oscilloscope during the time interval of one second at the beginning of each loading that lasted for 15 minutes.

The graphic presentation of the obtained impulses of the first second from the first minute is shown in picture 7. In the experiment we got a huge number of small impulses along the amplitude, which can be treated as a murmur and which drastically affect the decrease of the mean square value. On the other hand, in all cases we had the impulses of big amplitudes, more of them with a positive sign than a negative one. From this we can conclude that in the mentioned sample of oil there were generated much more positive than negative charges and that the electromotor force of the charged droplet in the tank truck e_k , more often experiences an increase than decrease.

We performed filtering of small signals, i.e. murmurs, by mathematics, so that we shall simply not take them into account in averaging, and we did averaging arithmetically, separately for positive and negative impulses.

4.3 Oscilloscoping of the impulse electric charge discharging, [1,2].

Let us analyze one of the observed intervals $t \in (0 \text{ min } 0s, 0 \text{ min } 1s)$, presented in Fig.7 .

Let us conduct the analysis: since, according to Fig. 7, we marked positive impulses of sufficiently big amplitudes with numbers from 1 to 15, and negative sufficiently big impulses with numbers from 1 to 10, the mean values of the positive amplitude V_{sr}^+ and negative one V_{sr}^- of the voltage u_{12} can be expressed as follows:

$$V_{sr}^+ \text{ mV} = \frac{1}{n^+} \frac{r_1^+ \text{ mV / pod}}{r_2^+ \text{ mV / pod}} \sum_{i=1}^{n^+} l_i^+ \text{ mm} \quad , \quad \text{and}$$

$$V_{sr}^- \text{ mV} = \frac{1}{n^-} \frac{r_1^- \text{ mV / pod}}{r_2^- \text{ mV / pod}} \sum_{i=1}^{n^-} l_i^- \text{ mm} \quad (3)$$

where: n^+ and n^- - are adequate numbers of the sufficiently big positive and negative impulses $r_1^+ \text{ u [mV/pod]}$, $r_2^+ \text{ u [mV/pod]}$, and $r_1^- \text{ u [mV/pod]}$, $r_2^- \text{ u [mV/pod]}$, with the adequate proportion for positive and negative impulses $u \text{ } l_i^+ \text{ u [mm]}$, $i = \overline{1, n^+}$, $l_i^+ \text{ u [mm]}$, $i = \overline{1, n^-}$, $l_i^- \text{ u [mm]}$, of the length of positive and negative impulses .

With the change of adequate values from picture 7, and placing them in the formula (3) and (4) for the interval $t \in (0 \text{ min } 0s, 0 \text{ min } 1s)$, we get

$$V_{sr1}^+ = \frac{1}{15} \frac{12.5 \text{ mm}}{15 \text{ mm / pod}} (29+13+7+12+7+6+31+8+11+6+9+42+29+19+14) \text{ mm} = 13.5 \text{ mV}$$

$$V_{sr1}^- = \frac{1}{10} \frac{12.5 \text{ mm}}{15 \text{ mm / pod}} (14+11+6+6+37+11+10+6+5+5) \text{ mm} = 9.25 \text{ mV}$$

where:

$$n^+ = 15 \quad ; \quad n^- = 10 \quad ; \quad r_1^+ = r_1^- = 12 \text{ mV / pod} \quad ;$$

$$r_2^+ = r_2^- = 15 \text{ mm / pod} \quad ; \quad \sum_{i=1}^{15} l_i^+ = 243 \text{ mm} \quad \text{and}$$

$$\sum_{i=1}^{10} l_i^- = 114 \text{ mm}.$$

In the same way we get arithmetic mean values for other obtained diagrams in this experiment.

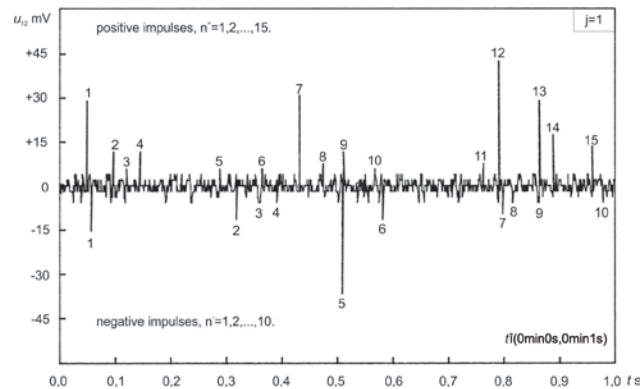

Fig. 7: Analysis of impulse discharging of the electric charge conducted according to the formula (3), [1, 2].

5 Probability of the distribution of electric charge generated in the interior of the oil tank model.

Analysis: gas-air space (gas mixture) – created electric field in the gas mixture .

Electric field in the gas-air space gets created due to the created electric charge of oil. The gas-air space is a concentration of the explosive mixtures of air and oil vapors, and is located in the gas-air space of the tank truck part (or oil tank, reservoir, etc.), partly filled with oil. This electric field is in principle inhomogeneous, because it is

made up of a partial electric field of the individual small charged droplets of oil. The breakthrough in some part of the gas mixture gets formed when the value of the electric field in that part exceeds the value of dielectric rigidity, which amounts to around one kilovolt per millimetre. The planar (cross) section of the tank truck model in real conditions with the adequate distribution of electricity is presented in Fig. 8. On the occasion of a breakthrough, there comes unloading between positive and negative ions, followed by sparking and emission of heat, which was also recorded in the experiment by a long exposure of the medical photographic film, Fig. 3. The probability of discharging in the gas mixture and its ignition depends on the pressure, p present in it, i.e. mean value of the distance $|\vec{E}| = f(t)$ between two neighboring spatially distributed charges (Fig. 8).

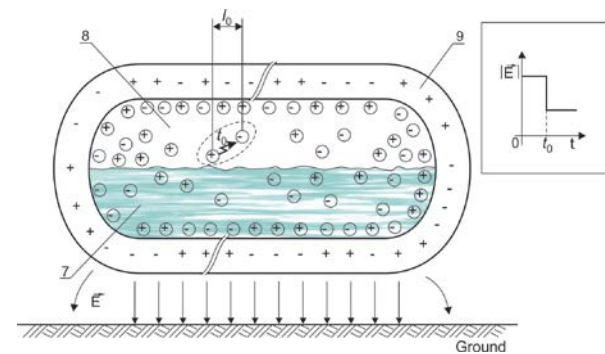

Picture 8: Planar (cross) section of the tank truck model in real conditions with adequate distribution of electricity, [1].

Picture description: display of the electric charge carriers and induced charges with an adequate distribution in the tank truck cross section. In the real conditions located at the truck stand with tyres, it has the value $R_{tvr} \approx 5 \text{ M}\Omega$ and capacitivity with regard to earth $C_{\text{tank-earth}} \approx 100 \text{ pF}$, with the display of the electrostatic field lines and diagram of change $|\vec{E}| = f(t)$; where: 7 – is oil (or oil derivative); 8 – gas-air space of the tank truck; 9 – metal wall of the isolated tank truck with regard to earth; l_0 - mean value of the distance between two neighboring spatially distributed charges in the time t_0 with the display of mutual discharging.

Let us conclude that the density of ions, and because of that even the probability of a breakthrough close to the metal earthed walls (barrier) of the tank truck, is bigger inside, and that is the case for the following reasons:

a₁.) All electric charges in the gas mixture are tied and which with their field in the metal walls of the tank truck result in the induced charges of the same intensity and opposite signs;

a₂.) The electric charges of the gas mixture and electric charges induced by them get mutually attracted, due to which the electric charges of the gas mixture move towards the tank truck walls (presented in Fig. 4);

a₃.) The movement of the charged droplets of oil or oil derivative towards the metal walls of the tank truck increases their density and pressure directly close to the walls, which results in a bigger probability of a breakthrough; and

a₄.) What can happen on the surface of the metal tank truck is condensation of both uncharged and charged droplets. If the layer of the charged droplets is placed over the layer of the uncharged ones, there happens the formation of the film of charged droplets, isolated from the metal walls of the tank truck. The field of this electric charge increases with their number, which also results in a breakthrough.

For $r = l_0$ by shifting the formula (12) to (14) we get,

$$|\bar{E}| = \frac{1}{4\pi\epsilon_0} \frac{q}{l_0} = \frac{q}{4\pi\epsilon_0 k_s} \sqrt{\frac{p_q^2}{m_q}} \quad (4)$$

Namely, a potential accidental case will take place when the value of the field, presented in the formula (4), at some point in space inside the tank truck exceeds the value of dielectric rigidity of the gas mixture, which amounts to around 1 kV/mm, and then a breakthrough of the formed gas dielectric will happen [5-17]. Then, according to picture 8, there comes unloading between positive and negative ions (at the point in time t_0), and also emission of heat, increase of the local value of temperature and appearance of illumination on the surface of the liquid phase. With the increase of temperature of the established gas, in accordance with the formula (4), at the constant value of the gas mass m_q , the value of the partial pressure of the charged particles increases p_q , due to which distance l_0 decreases and intensity of the electric fields

$|\bar{E}|$ increases, getting the value of [1, 2]

$$q_k = q_{12} = C_{12} u_{12} = 50 \cdot 10^{-12} \cdot u_{12} \text{ mV}, \quad \text{or}$$

$$q_k [C] = k_q \cdot u_{12} \text{ mV}, \quad (5)$$

where: k_q - is the constant having the value, $k_q = 50 \cdot 10^{-15} \text{ C/mV}$ and brings about the electric breakthrough.

Conclusion: If the number of such dischargings is sufficiently big, then in some part of the space the critical density of energy may be exceeded and ignition of the formed gas mixture may happen.

6. Probability and calculation of the time of breakthrough and ignition of the gas mixture, [1, 2].

The result of the conducted experimental research gives the number of positive impulses of the impulse discharging of static electricity on the oscilloscope, $N^+ = 297$, number of negative impulses $N^- = 181$ and the total number of impulses $N = N^+ + N^- = 478$, which recordings lasted one second each during the interval of 15 minutes, i.e. in the overall time interval of 15s. Based on that, the mean value of the impulse frequency f_{sr}^+ and adequate periods

T_{sr}^+ and T_{sr}^- , total:

$$f_{sr}^+ = \frac{N^+}{t \text{ s}} = \frac{297}{15 \text{ s}} = 20 \text{ Hz} \quad ; \quad \text{and}$$

$$f_{sr}^- = \frac{N^-}{t \text{ s}} = \frac{181}{15 \text{ s}} = 12 \text{ Hz} \quad (6)$$

$$T_{sr}^+ = \frac{1}{f_{sr}^+} = 50 \text{ ms} \quad ; \quad \text{and}$$

$$T_{sr}^- = \frac{1}{f_{sr}^-} = 83 \text{ ms} \quad (7)$$

Since each value of the quantity of electricity q_k^+ or q_k^- has a corresponding voltage value V^+ or V^- , by transforming the quantity of electricity into voltage the same diagrams can be used for determining the probability $P(V^+ \geq V_i^+)$ or $P(|V^-| \geq |V_i^-|)$ of the distribution of amplitudes of positive and negative impulses, as well as the intervals of confidence $V^+(P)$ or $|V^-|(P)$ of the amplitudes of these impulses, [1, 2]. For example, for the tank truck of the volume of 36 tons, the critical time of ignition of the formed gas mixture in the gas-air space of the tank truck is t_{krpc} , caused by discharging static

electricity, so the intervals of confidence $t_{krpc}(P = 0.5)$ and $t_{krpc}(P = 1.93 \cdot 10^{-9})$ of the time of ignition of the gas mixture will be, [1, 2]

$$t_{krpc}(P = 0.5) = 34.8 \text{ s} , \quad \text{and} \\ t_{krpc}(P = 1.93 \cdot 10^{-9}) = 1.2 \text{ s} \quad (8)$$

The result (8) points to a big danger that exists in the conditions of transporting or loading of fuel in using tank trucks, even the oil tanks and reservoirs and other geometric shapes of big volumes. This fact justifies the needs for applying most modern and highly reliable systems of elimination of static electricity and protection against ignition and explosion of the gas mixture. The obtained results of the analysis indicate and prove the existence of the latent danger in the technological procedure of loading oil and oil derivatives and their transporting. The elimination of static electricity in the mentioned technological procedures is mandatory as a safety measure. In the study we assessed and presented parameters of unavoidable events arisen during the technological process of loading, which served as characteristic values for a correct theoretical support to the necessary need of designing and constructing the passive device for elimination of static electricity.

7. Presentation of the calculated values, [1, 2].

The results of the conducted research and then conducted analyses are as follows:

b1.) By examining the equivalent scheme of the model of tank truck for transportation of oil, and based on the detailed analysis, we came to the conclusion that the tank truck moving or in the regime of loading, and that is the case when static electricity gets generated, can be presented as a generator of the electricity quantity with the exit voltage of u_{12} .

b2.) For the lonely droplet of oil, charged with the electricity quantity $q_k = 8.65 \text{ pC}$, it was shown that the volatage on the capacitivy of the tank truck, u_{12} must not be bigger than 173 mV in order to avoid discharging of static electricity in the gas mixture of the gas-air space of the tank truck model (picture 3).

b3.) It was also shown that for the ignition of the gas mixture it is necessary to have stacked on the metal inner surface of the tank truck model more than 56000 of such

electric charges and activated their joint and simultaneous unloading.

b4.) These electric charges, on the surface $S_{kr} = 7.18 \text{ cm}^2$, with the uncharged oil layer of width less than $l_{kr} = 78 \text{ }\mu\text{m}$, form the total capacitivy of the charged and condensed droplets of oil in the time $t_i = t_j$, and for the value of the differential capacitivy $C_d = C_{ku}$ on the border of the twofold layer liquid - solid phase, what follows is ($t_i = t_j$; $C_d = C_{ku}$).

$$C_{ku} \square \varepsilon_r \cdot \varepsilon_0 \frac{S_{kr}}{l_{kr}} = 2 \cdot 8,85 \cdot 10^{-12} \frac{7.18 \cdot 10^{-4}}{78 \cdot 10^{-6}} = 163 \text{ pF} \quad (9)$$

where the adopted value of the relative dielectric constant of oil $\varepsilon_r = 2$.

b5.) The voltage on the capacitivy C_{12} of the tank truck now has the shape,

$$u_{12} = E_{ku} \frac{C_{ku}}{C_{ku} + C_{12}} , \quad (10)$$

Where E_{ku} represents the electromotor force of the whole layer, of the charged particles – aggregate of electric charge, the electric load of which amounts to $q_{kr} = 0.5 \text{ }\mu\text{C}$.

Now we have that:

$$E_{ku} = u_{k \text{ max}} + u_{12} = u_{k \text{ max}} + E_{ku} \frac{C_{ku}}{C_{ku} + C_{12}} ,$$

what follows is

$$E_{ku} = \frac{u_{k \text{ max}}}{1 - \frac{C_{ku}}{C_{ku} + C_{12}}} = \frac{C_{ku} + C_{12}}{C_{12}} u_{k \text{ max}} \quad (11)$$

By shifting the result (9) and the previously adopted value $u_{k \text{ max}} = 1 \text{ KV}$ and $C_{12} = 50 \text{ pF}$ in the formula (11) we get

$$E_{ku} = \frac{1 \text{ KV}}{1 - \frac{163}{163 + 50}} = 4.26 \text{ KV} \quad (12)$$

The electric field in the dielectric of such capacitor E , will be

$$E = \frac{2\eta}{\varepsilon} = \frac{2q_{kr}}{\varepsilon S_{kr}} = \frac{2q_{kv}}{\varepsilon_r \varepsilon_0 S_{kv}} =$$

$$= \frac{0.5 \cdot 10^{-6}}{8.85 \cdot 10^{-12} \cdot 7.18 \cdot 10^{-4}} = 79 \frac{MV}{m} = 79 \frac{KV}{mm} \quad (13)$$

$$\text{where } \eta = \eta_{kr} = \frac{q_{kr}}{S_{kr}} = \frac{0.5 \cdot 10^{-6}}{7.17 \cdot 10^{-4}} = 0.7 \frac{mC}{m^2} \quad (14)$$

represents a critical value of the surface density of electric charge that results in the breakthrough of the oil dielectric layer and ignition of the gas mixture [1-10]. By shifting the already obtained results in the formula (10), we find out that

$$u_{12} = 4.26 \text{ KV} \cdot \frac{163}{163+50} = 3.26 \text{ KV} \quad (15)$$

If we remember previous analyses regarding the increase of voltage u_{12} , we can say the following; in the beginning the capacitivity C_{ku} was minimal and amounted to $C_{ku} = C_u = 8.65 \text{ fF}$, while the voltage u_{12} amounted to $u_{12} = 173 \text{ mV}$, and by gathering electric charge on the inner surface of the tank truck and forming aggregate electric charge there comes the increase of capacitivity C_{ku} , and voltage as well u_{12} up to the value that could amount to several kilovolts.

8. New Passive Solution for Elimination of Static Electricity in the Considered Technological Procedure of Loading [1,2]

In accordance with the stated proofs, we are presenting a proposal of the new method of passive elimination of static electricity [1]. The principle of work of the passive solution is presented in Fig. 9. The model of electric circuits for passive elimination of static electricity was realized with two electric circuits: *circuit for controlled re-pumping of the formed electric charge*, and *circuit for elimination of static electricity*, which is presented in Fig. 9. **Electric** circuits for passive elimination of static electricity (as the entirety block) are connected by one end to the tank truck where oil or oil derivatives are loaded, and by the other end to the existing earthing switch. Supplying of now passive device for elimination of static electricity PU with electric power is performed by the formed charge during loading of oil to the tank truck. The technical performance of the mentioned device for elimination of static electricity is the anti-explosive protection Ex s || 1 GD. The PU device is composed in a block of two electric circuits, those being, [2]:

- electric circuit for controlling re-pumping of the formed electric charge, controls re-pumping of the formed charge from the surface and from within the tank truck model. The controlled re-pumping of the formed electric charge gets realized by the passive high-voltage elements RLC, by determining time constants in the process of re-pumping electric charge, [2] and
- electric circuit for elimination of static electricity where the controlled re-pumped electric charge, i.e. in that way controlled re-pumped created electrostatic energy gets converted with a control to a heat energy. The stated procedure happens so that there is no cumulative discharging of the created static electricity in the tank truck, both inside at the depth of oil, but also on the surface of oil in the gas-air space, [2].

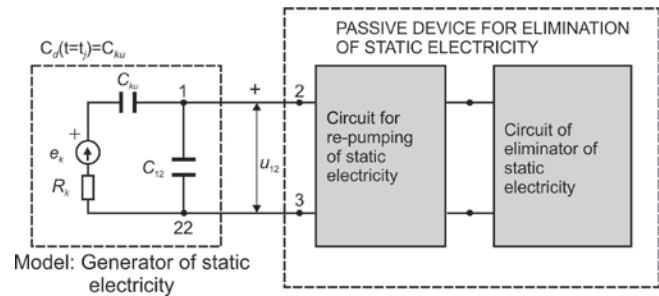

Fig. 9: Schematic presentation of the proposed passive device for elimination of static electricity connected to the source of the static electricity established in the borderline layer of the contact of the twofold layer of oil (or oil derivative) – inner metal wall of the tank truck model, [1, 2].

9. Demonstration of working functions

We shall perform demonstration of the working functions of the proposed passive device for elimination of static electricity by comparing its behavior on the tank truck model intended for the elimination of static electricity with the behavior of the cam switch (single-pole switch made by EEx d || AT3) intended for the same purpose.

9.1 Cam switch, in accordance with the adequate technical regulations, is used for earthing metal parts of the tank truck (as well as other volumes and transporting and storing systems), and electrotechnic equipment as well, for the purpose of eliminating static electricity in the technological procedure of loading oil, oil derivatives, dangerous matters and liquids and gas. Because of that, we shall here conduct the procedure of comparison for the cases when the tank truck is earthed through a cam switch, GS, and the case of earthing the tank truck through the proposed passive device for elimination of static electricity.

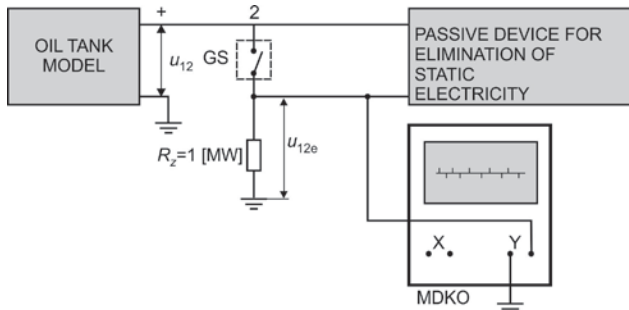

Fig. 10: Functional test of the efficiency of work of the passive device for elimination of static electricity (PU) in the laboratory and real conditions, by comparing results of elimination of static electricity obtained by earthing the tank truck through a cam switch (GS) and device (PU) on the oscilloscope (MDKO) [1,2].

9.2 *Performing demonstration of the comparison* is done on the tank truck model, presented in picture 10. The tank truck model, both in real and laboratory conditions, implies a state of tank truck in which liquid phase (in the concrete case oil and oil derivatives) is loaded or stored. In the same way according to picture 10, the demonstration is conducted of the results of the performed elimination of static electricity in real conditions and observed through the laboratory correct examinations and examinations in real conditions of loading. Namely, in our research we modeled the tank truck so that what is implied here is generating of static electricity in the liquid phase of the tank truck and natural taking out of it to the metal wall of the tank truck (presented in picture 9). Such a state enables comparison of these two mentioned methods. The goal of this procedure of comparison of the mentioned methods is the assessment of validity and reliability of each method from the aspect of requirements of the elimination of the created and established static electricity in a dangerous technological use of the tank truck.

The result of the conducted comparison, based on the procedure presented in Fig. 10, is shown through the diagrams in Fig. 11 and 12.

9.2.1 Description of the procedure of comparison and obtained results

The tank truck model, presented in Fig. 10, can be earthed to the earthing switch in two ways:

- *directly, through a cam switch, GS*, as prescribed by the technical regulations. Fig. 11 presents the results of the use and of cam switch, GS. By subjecting the exit voltage $U_{12}(t)$ to the operations of adequate integrating and reinforcing, it is possible to get the time dependence of voltage that is by shape and by value equal to the electro

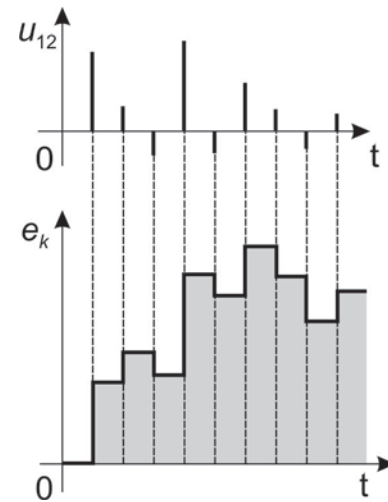

Picture 11: Procedure by item 9.2.1.1 – Earthing of the tank truck, directly through a cam switch; Presentation of the one-way electromotor force e_k of the equivalent generator of the tank truck model, while voltage is a differentiated value of e_k in time t , and in case of earthing the tank truck model through a cam switch (GS), presented in this picture, [1, 2].

With this we prove a big danger caused by static electricity in the technological work of re-pumping with the tank truck.

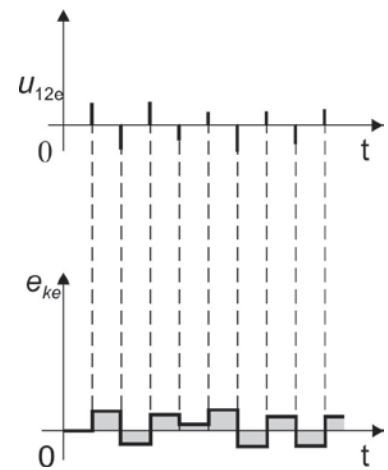

Picture 12: Procedure by item 9.2.1.2 – Earthing of the tank truck, through the proposed passive device for elimination of static electricity; Presentation of the state of earthing the tank truck model through the proposed passive device for elimination of static electricity. Now the values of voltage $u_{12} = u_{12e}$ and one-way electromotor forces $e_k = e_{ke}$ are smaller in time t , [1, 2].

With this we prove a complete safety of the technological work of re-pumping with the tank truck.

motor force $e_k(t)$ at the entrance of the scheme in Fig. 13. What happens in that case on the surface of oil that is located in a partly filled tank truck and gas-air space of the tank truck, is explained and presented in Fig. 1, 2 and 3. By subjecting the exit voltage $U_{12}(t)$ to the operations of adequate integrating and reinforcing, it is possible to get the time dependence of voltage that is by shape and by value equal to the electromotor force of the charged droplet of oil $e_k(t)$.

What happens in that case on the surface of oil that is located in the partly filled tank truck and gas-air space of the tank truck, is explained and presented in Fig. 1, 2 and 3.

Experience based on the conducted tests: earthing of the tank truck directly through a cam switch represents a big latent danger in the technological procedure of loading oil and oil derivatives, and that means appearance of fires and explosions. We propose that the technical regulations responsible for elimination of static electricity should in the given technological procedure ban the use of a cam switch intended for elimination of static electricity.

- directly, through a passive device, when the cam switch GS is turned off, the proposed passive device for elimination of static electricity, PU is connected to the exit of the tank truck model. The results of the use of the passive device for elimination of static electricity are presented in picture 12. Namely, what becomes distinct is its function of the controlled re-pumping of electricity from the tank truck model to the proposed passive device for elimination of static electricity, PU. Because of that, the increase of the quantity of electricity in the tank truck model will be much smaller. What corresponds to this increase are the differentiated impulses u_{12e} and electromotor force e_{ke} on the capacitance C_{12} , of the amplitude of several milivolts and which oscillates around the zero value. By this, dispersion of heat in the tank truck model will be neglectable. The heat that develops in case of work of the cam switch GS, actually develops within the gas mixture of the tank truck model. In the work of the proposed passive device, PU, the established heat gets developed inside it. That is the reason why the proposed device, PU is designed in accordance with the anti-explosive regulations. By turning off the proposed passive device and oscilloscope and by connecting the electrostatic voltmeter to the exit voltage u_{12} of the tank truck model, we shall see that this voltage is close to zero; that is normal since the voltage u_{12} , with the oscilloscope turned off and the proposed passive device, PU turned on, will have the

value of e_{ke} , which is also small. Experience based on the conducted tests: we propose the use of the passive device in elimination of static electricity, PU when loading and storing oil and oil derivatives and gas and easily flammable liquids.

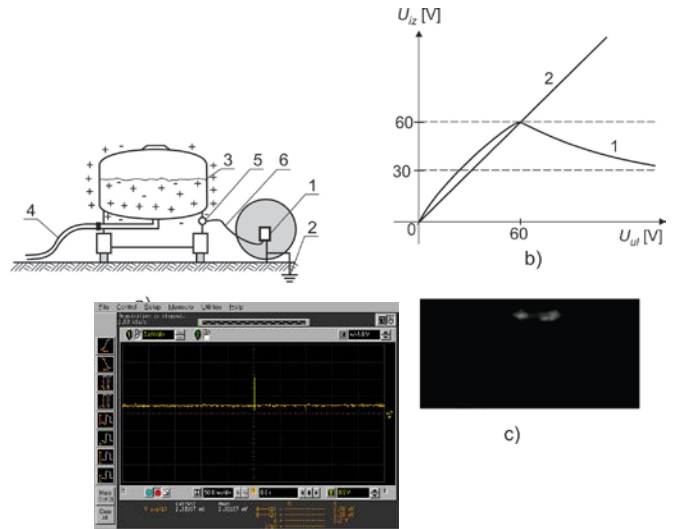

Fig. 13: Presentation of basic characteristics of the proposed and realized passive device for elimination of static electricity, PU [1, 2].

Description and comment of Fig. 13 ;

Fig. 13 a); presents manner of connection PU 1, on tank truck 3, which loads oil (or oil derivative) with hose 4, while PU is connected to point 5 and point 2 to earthing switch, which is identical according to pictures 16 and 18.

Fig. 13 b); presents entrance-exit characteristic of PU obtained by comparison presented in pictures 18 and 19, where 1 – characteristic of PU, 2 – characteristic of cam switch in this case serves only for direct earthing of tank truck to the united earthing switch, intended for the standard-based elimination of static electricity for conditions from picture a). Characteristic was done in the computer program based on the results of measuring in the laboratory conditions.

Fig. 13 c); presents recorded state on the surface of oil in the earthed tank truck across the proposed PU, by the principle of photographing given state by the medical photographic film, and explained in Fig. 3 and 10. The picture makes it evident that there was established a balance state of the energy exchange of electrostatic energy (reduced to the dangerless state of exchange) between oil and metal wall – which represents passive elimination of static electricity by the proposed passive device PU.

Comment: In case of application of the proposed PU we cannot notice discharging (white stains) on the surface of oil, which is confirmed in Fig. 14. The case of connection of a cam switch for the purpose of a direct earthing of the metal tank truck to the unite earthing switch is presented in Fig. 1 and 2.

What happens in the considered case when the cam switch GS is turned off, we comment and present in picture 14. By this we proved the advantage of the proposed PU over the direct earthing through the cam switch intended for elimination of static electricity in the technological process of loading and storing of oil and oil derivatives in tank trucks and other similar geometric shapes.

9. CONCLUSION

The objective of this study was to present some events in the contact of a twofold layer of oil (and oil derivatives) in the technological process of loading. In the partly filled metal tank truck (and also in the metal reservoir or some other similar volume geometry), the events take place in the zones of contact of the twofold layer as the borderline area. We analyzed the zones of contact of the twofold layer both with oil-metal wall of the tank truck, but also between oil and gas-air space and even very carriers of electric charge in the depth of oil. The events that took place were examined and analyzed, and also the potential future events of the potential exchange of created electrostatic energy of the state phases were anticipated. The anticipated events can be treated as accidental cases that dangerously endanger safety in the work of the technological process of loading and storing of oil and oil derivatives. For the purpose of providing safe considered technological procedure there is a proposal of the possible safe manner of passive elimination of static electricity – with the passive device for elimination of static electricity.

Acknowledgments

This paper is dedicated to dear late Prof. Dr Dragutin M. Veličković.

References

[1] M. Gaćanović: “Nove mogućnosti pasivne eliminacije statičkog elektriciteta”, doktorska disertacija, (PhD thesis), Univerzitet u Banjoj Luci, Elektrotehnički fakultet, Banja Luka/Niš/Beograd, Bosna i Hercegovina/Srbija, 2002. (In Bosnia and Herzegovina / Serbian) .

[2] M. Gaćanović: “Uređaj za eliminaciju statičkog elektriciteta kod pretakanja nafte, naftnih derivata, zapaljivih i opasnih tečnosti i gasova tip EL-1 N/S ” (*Device for static electricity*

elimination used during racking, transportation and loading/unloading of inflammable or explosive materials tip EL 1 N/S); YU Patent 48839 ; German; Patent No. 699 14 225 ; European Patent EP 1 169 88 ; Canadian Patent No. 2,401,517 ; European-Asian Patent & Patent Russia No. EA 003411 ;, 1998 – 2013.

[3] M. J. Živanić: “Prilog rešavanju elektrostatičkih polja u anizotropnim sredinama sa posebnim osvrtom na primenu metoda fiktivnih izvora”, doktorska disertacija, (PhD thesis), Univerzitet u Nišu, Elektronski fakultet Niš, Čačak, 1986. (In Serbian).

[4] D. M. Veličković, S. R. Aleksić: “Primena metoda ekvivalentne elektrode na rešavanje niskofrekventnog uzemljenja”, II Srpski simpozijum iz primenjene elektrostatike PES '86, Niš, 1986., (pp.) str.7.1-7.6. (In Serbian).

[5] A. Klinkenberg, J. L. Minne: *Electrostatics in the Petroleum Industry*. Amsterdam, London, New York, Princeton, 1958.

[6] BS 6651: Code of Practice on Lightning Protection, British Standard Institution, 1985.

[7] *Lightning Protection Code*, NFPA 78; National Fire Protection Agency (USA), 1978.

[8] M. D. Veličković, M. Gaćanović: O metodi srednjih potencijala, *Zaštita* 35 (5), Sarajevo, 1986.

[9] American Petroleum Institute; Interim Report, Tanker Accident Study Committee, November, 1970. & 1971., *Statics Research Program Part One : (1974 a) Charge Transfer Between Isolated Conducting Objects and Ground in a Tank Filled with an Electrically Charged Mist & Statics Research Program Part Two; (1974 b) Water Slug Formation During Tank Washing; (1974c) Final Report, Tanker Accident Study committee, November 27, 1974.; Recommended Practice 2003 (1982). Protection Against Ignitions Arising Out of Static, Lightning and Stray Currents.*

[10] J. V. Surutka, D. M. Veličković: “Some Improvements of the Charge Simulation Method for Computing Electrostatic Fields”, *Bulletin LXXIV de l'Academie Serbe des Sciences et des Arts, Class des Sciences technique*, No. 15, 1981, pp. 27-44.

[11] D. M. Veličković: “Equivalent Electrodes Method Application for Electrostatics Problems Solving”, *The Third International Symposium on Applied Electrostatics, PES '90, Niš 1990*, pp. 7-27.

[12] K. Asano, A. W. Bright: “Space - Charge - Influenced Current in a Dielectric Liquid ”, *Journal of Physics D: Applied Physics*: Vol. 4, No. 9, 1971, pp. 1306-1314.

[13] K. Asano, H. Kramer: “ On the Estimation of Ionic Mobilities in Dielectric Liquids from Charge Relaxation Studies ”, *Journal of Electrostatics* Vol. 2, No. 3, 1976, pp. 269-276.

[14] K. Asano: “ Electrostatics Potential and Field in a Cylindrical Tank Containing Charged Liquid ”, *Proc. IEE* 124, Vol.124, No.12, 1977, pp.1277-1281.

[15] H. Kramer, K. Asano, G. Shlon: “ Criteria for Safe Filling of Tank Vehicles - Theoretical and Experimental Studies to Assess the Electrostatic Hazard ”, *Third International Congress on Static Electricity, Grenoble, 1977, paper N₀ 31a.*

- [16] International Chamber of Shipping; (1970) Interim Report on Explosions in Very Large Crude Carriers ; (1971) Second Report on Explosions in Very Large Tankers ; (1973) Third Interim Report on Explosions in Very Large Tankers ; (1975) Final Report on Explosions in Very Large Tankers.
- [17] CRC Report ; 355 (1961) Electrostatic Discharge in Aircraft Fuel System - Phase II. Coordinating Research Council, Atlanta, Ga. ; 455 (1973) The Electrostatic Charging Characteristics of Jet Fuel Filtration Equipment. Coordinating Research Council, Atlanta, Ga. ; 473 (1974) Electrostatic Charging Survey of Airport Fueling Systems. coordinating Research Council, Atlanta, Ga.
- [18] С. А. Бобровский, Е. И. Яковлев: Защита от статического электричества в нефтяной промышленности. М., Недра, 1983.
- [19] A. Klinkenberg, G. L. Minne: Electrostatics in the Petroleum Industry, Amsterdam-London- New York-Princeton, 1960.
- [20] N. J. Felici: “ Conduction and Electrification in Dielectric Liquids: Two Related Phenomena of the Same Electrochemical Nature ”, Journal of Electrostatics, 1984, Vol. 15, No.3, pp. 291-297.
- [21] N. Gibson: “ Electrostatic Hazards During Handling of Liquids in Industrial Situations”, Industrial electrostatics, International Conference on Industrial Electrostatics, Budapest, 1984, pp. 6-33.
- [22] D. M. Veličković: Metodi za proračun elektrostatičkih polja, Knjiga prva, Stil, Niš, 1982. (In Serbian)
- [23] J. V. Surutka: Osnovi elektrotehnike, Prvi deo, Elektrostatika, Naučna knjiga, Beograd, 1980. (In Serbian)
- [24] A. Despić, D. Drajić, O. Tatić-Janjić: Osnovi elektrohemije, Naučna knjiga, Beograd, 1970. (In Serbian)
- [25] D. M. Veličković: “ Approximate Solution of Electrostatics Problems”, STATICKA ELECTRINA, Krakow, October 1980, Approximate Solution of Electrostatics Problems, pp. 7-16.
- [26] J. V. Surutka: Osnovi elektrotehnike, Naučna knjiga, Beograd, 1982. (In Serbian)
- [27] D. M. Veličković: Analitički metodi za rešavanje problema elektrostatičke, Zbornik radova, III Jugoslovenskog savetovanja o statičkom elektricitetu, ELEKTROSTATIKA 78, oktobar 1978. (In Serbian)
- [28] J. V. Surutka, D. M. Veličković: “ Jedan numerički metod za izračunavanje otpornosti uzemljenja toroidalnih uzemljivača“, XII Jugoslovenski internacionalni simpozijum, Informatika 77, Bled, 3-8 oktobar 1977, str.196-209. (In Serbian)
- [29] J. V. Surutka, D. M. Veličković: “ Elimination of the Static Atmospheric Electricity From the Guys of MW and LW Broadcast Tower Antennas “ , International Conference: Industrial Electrostatics, Budapest, 1984.
- [30] F. Tanasescu, R. Cramariuc: Electrostatica in tehnica, Bucuresti, Editura tehnica, 1977.

Author :



Prof. Dr. Mićo Gaćanović was born in 1952. He is recognized and known internationally as a scientist in the field of applied electrostatics, where he has given his contribution through original solutions, which are patented in 136 countries throughout the world and applied in production. He received many prestigious world-known awards and certificates for his creative work. Hence, he is included in the work of world groups of creativity, research and new technology in Brussels, Moscow, Pittsburgh and other world cities. He is also involved in research projects in the field of theoretical electrical engineering in Germany, Belgium and Russia.